

*訂購時請將圖面連同訂單一併回傳。

*Please send back with order while ordering.

客戶確認 Confirmed

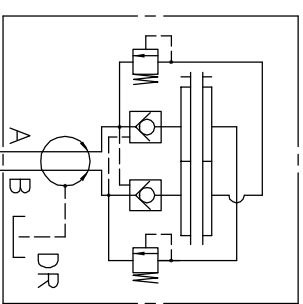
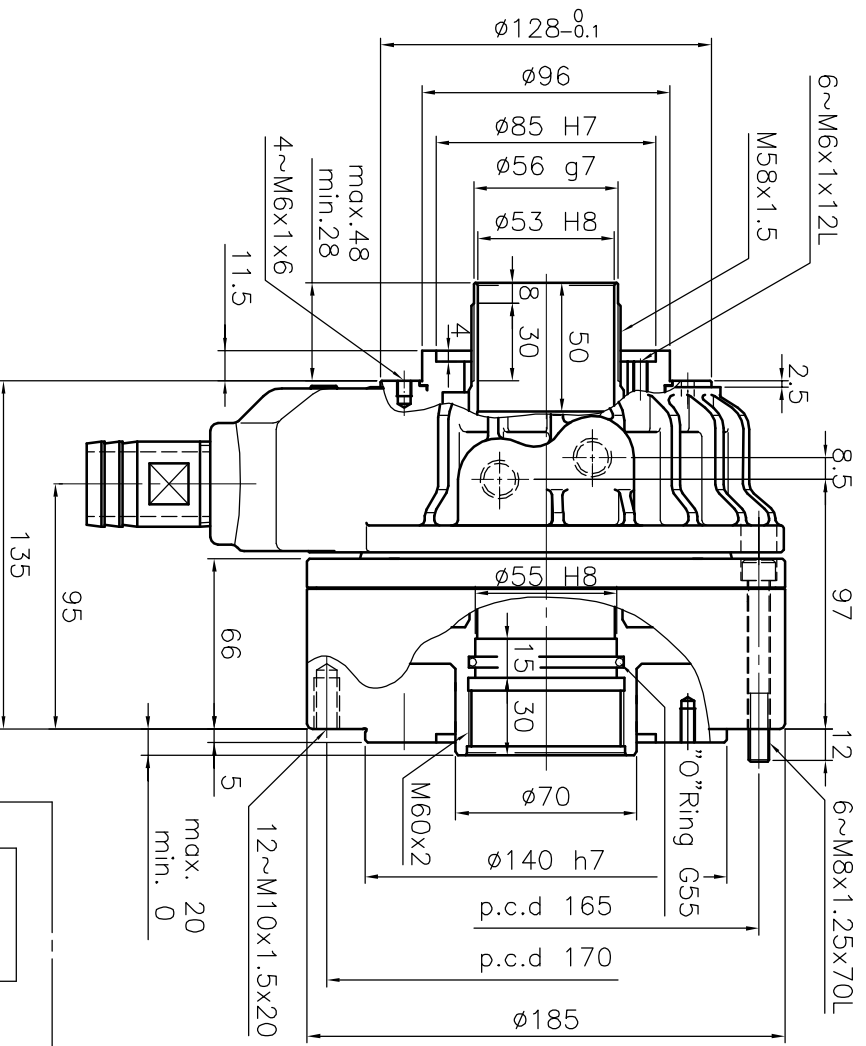
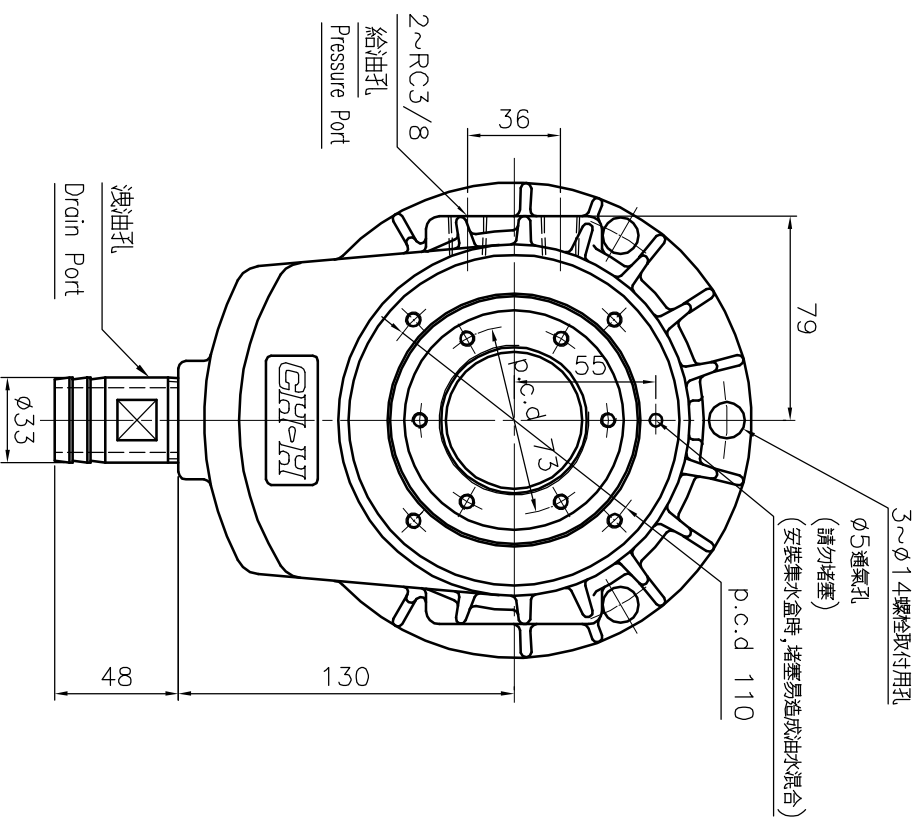

通孔徑 $\phi 53$

名稱 Name	超短型中空迴轉油壓缸 SHORT TYPE ROTARY HYD. CYLINDER
規格 Spec. 型號 Model	TK-A853
活塞面積 Eff. piston area	伸側 Extend cm^2 135.3 拉側 Retract cm^2 125
行程 Piston stroke	mm 20
最高使用迴轉數 Max. speed	r.p.m. 6300
最高使用壓力 Max. pressure	kgf/ cm^2 45
最高使用壓力 Moment of inertia	kgf m^2 0.032
重量 Weight	kg 11.8
總洩油量 Total oil leakage	liter/min 3.9

- 洩油孔管務必單獨接回油槽，以避免產生背壓。
- The drain port should be independently connected to oil tank to avoid back pressure.

*為確保產品品質日益精進，敝公司擁有設計變更之權。
*Subject to technical changes.