

*訂購時請將圖面連同訂單一併回傳。 *Please send back with order while ordering.

客戶確認 Confirmed

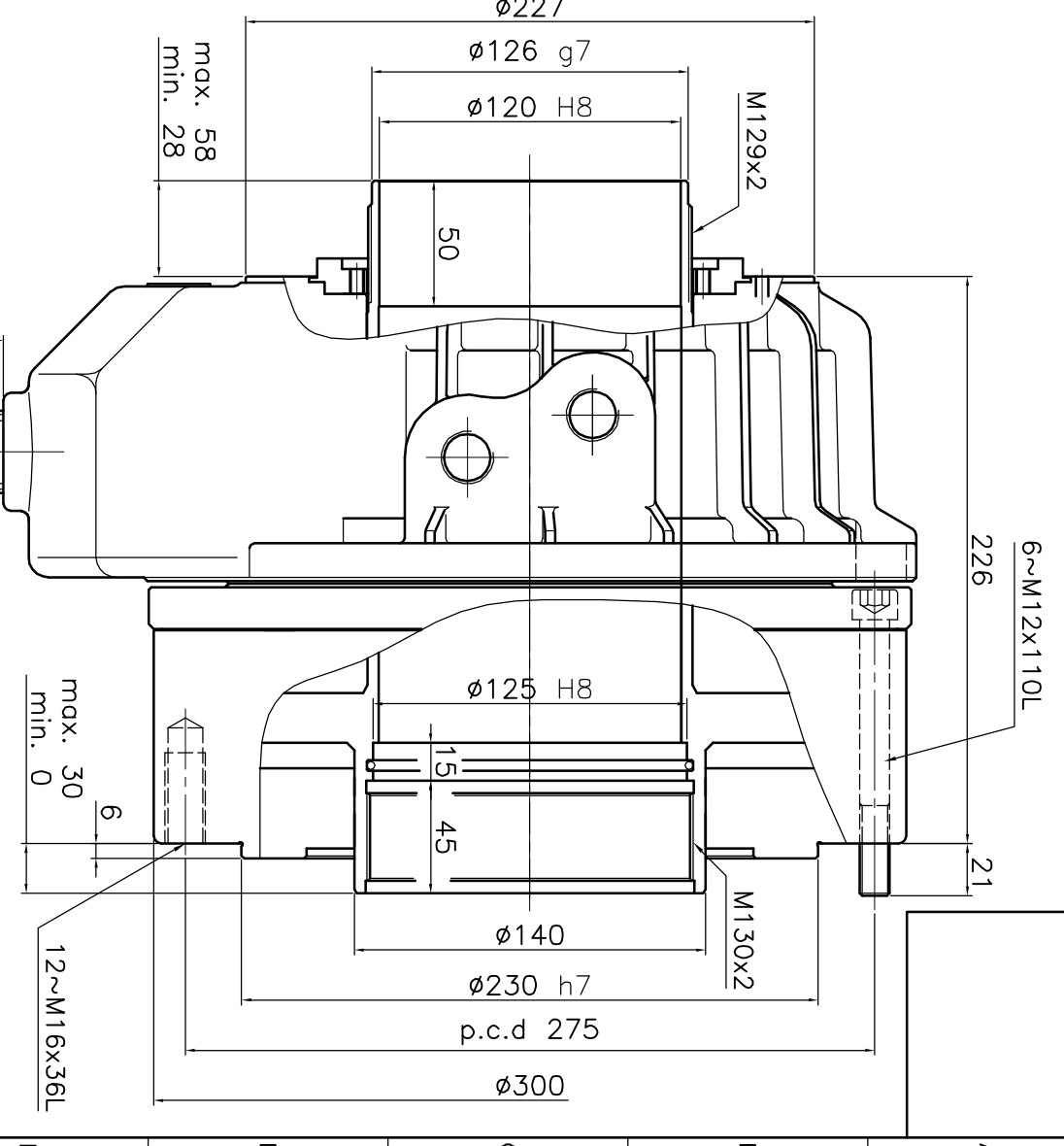

名稱 Name	中空迴轉油壓缸 ROTATING HYDRAULIC CYLINDER	
規格 Spec. 型號 Model	TK-A1512	
活塞面積 Eft. piston area	伸側 Extend cm ²	336.4
行程 Piston stroke mm	拉側 Retract cm ²	315.2
最高使用迴轉數 Max. speed r.p.m.		30
最高使用壓力 Max. pressure kgf/cm ²		3000
最高使用壓力 Max. pressure kgf/cm ²		35
最高使用壓力 Max. pressure kgf/cm ²		0.38
重量 Weight kgs		49.8
總洩漏量 Total oil leakage liter/min		7.0

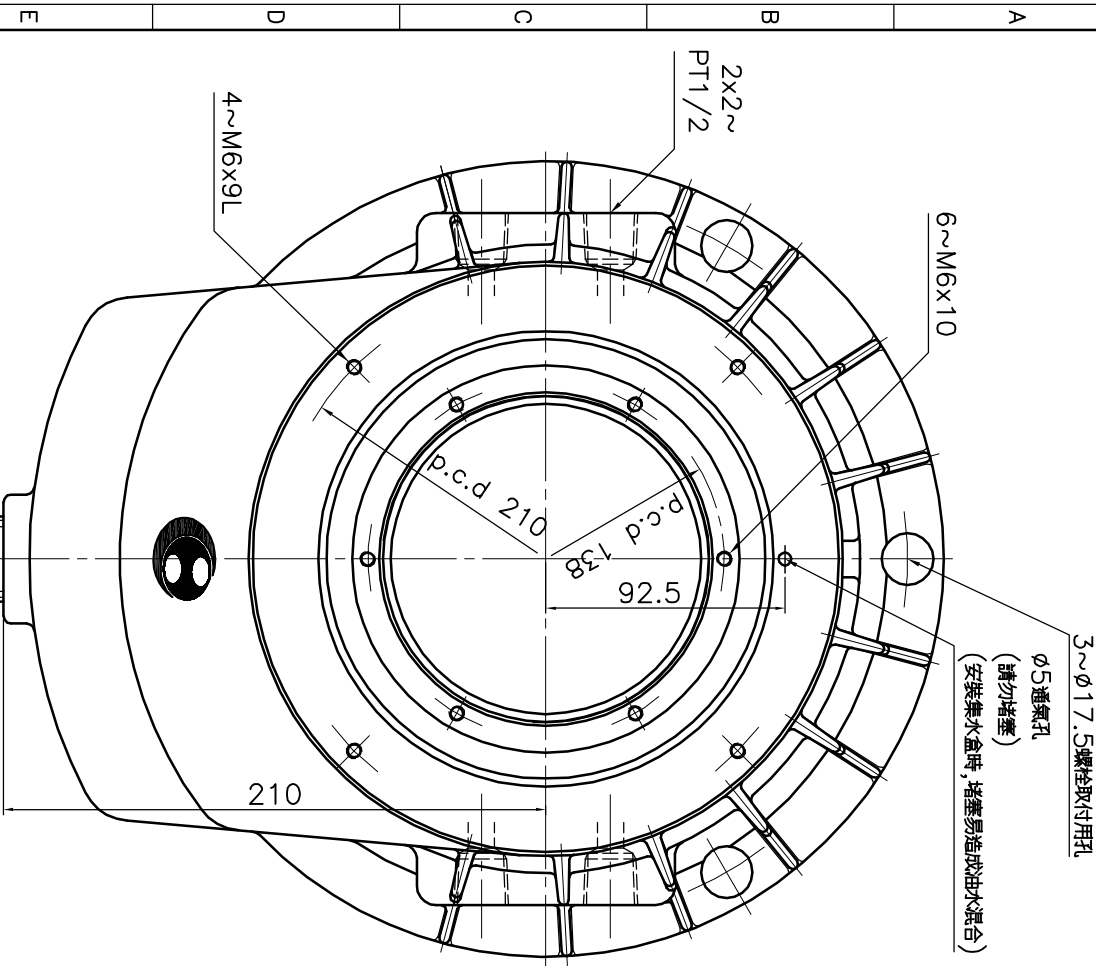
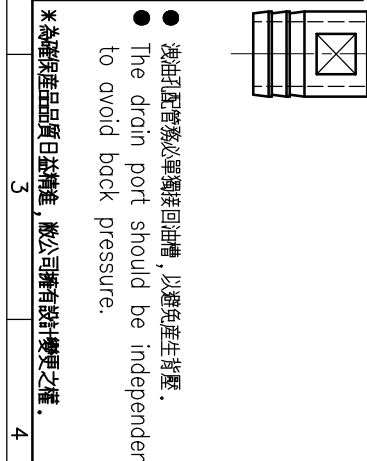

● 洩油孔配管務必單獨接回油槽，以避免產生背壓。
● The drain port should be independently connected to oil tank to avoid back pressure.

*為確保產品品質精益求精，敝公司擁有技術變更之權。
*Subject to technical changes.