

*訂購時請將圖面連同訂單一併回傳。 *Please send back with order while ordering.

客戶確認 Confirmed

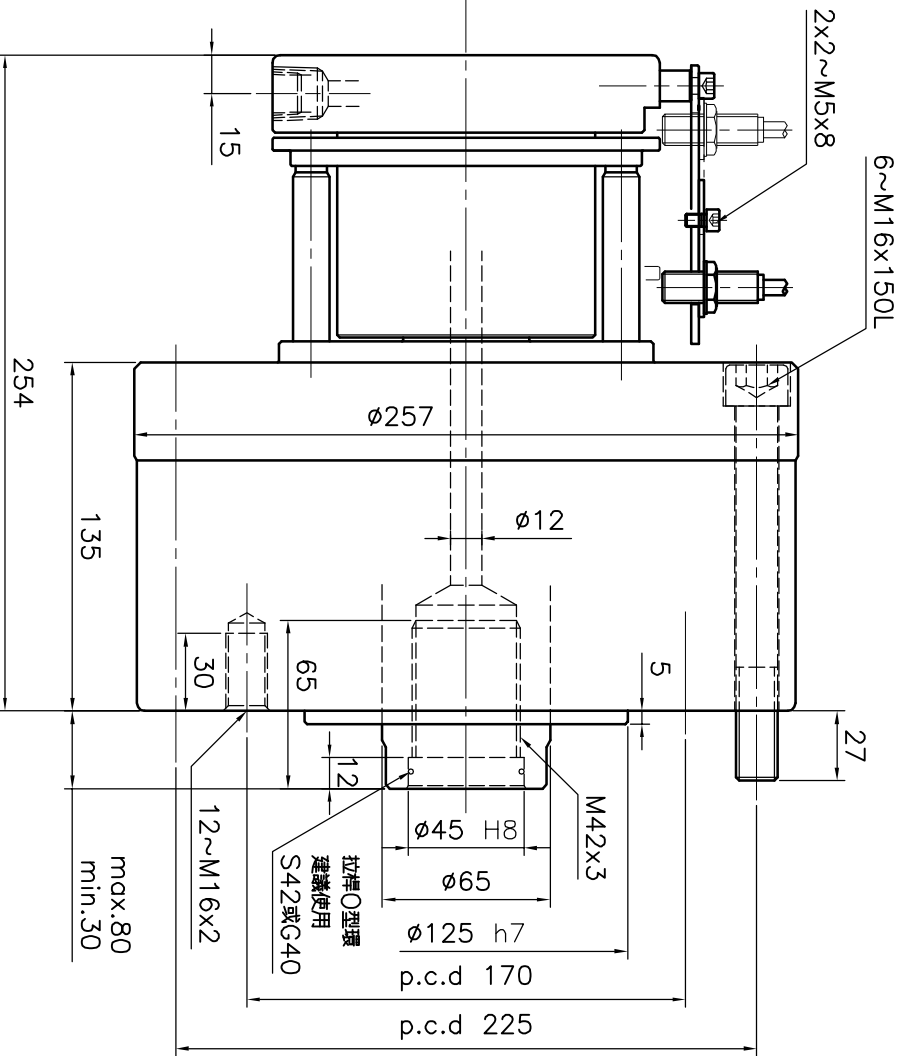
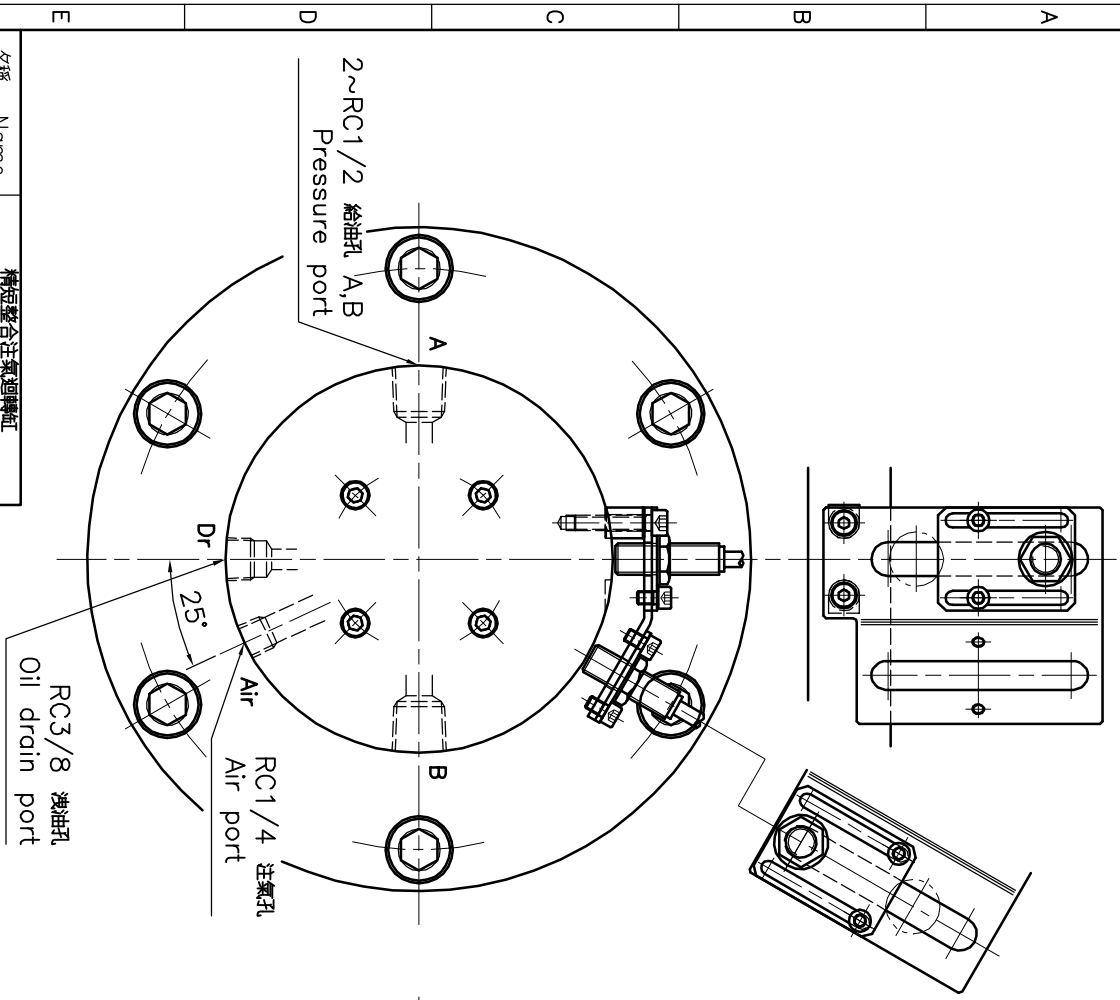

名稱	Name	精密整合注氣迴轉缸 COMPACT STYLE HYDRAULIC CYLINDER	
規格	型號 Model	RE-A200L	
活塞面積	伸縮 Extend	cm ²	292.4
拉縮 Retract	cm ²		265.4
行程	Piston stroke	mm	50
最高使用迴轉數	Max. speed	r.p.m.	4000
最高使用壓力	Max. pressure	kgf/cm ²	50
慣性力	Moment of inertia	kgf·m ²	0.21
重量	Weight	kg	30.4
總洩油量	total oil leakage	liter/min	2.0

- 油孔配管務必單獨接回油槽，以避免產生背壓。
- The drain port should be independently connected to oil tank to avoid back pressure.

*為確保產品品質精益求精，敝公司擁有設計變更之權。 *Subject to technical changes.