

1	2	3	4	5	6	7	8			
規格 Spec. 型號 Model	分度角度 Deg Index Angle	爪行程 mm Jaw Stroke	主軸內孔 mm Main Spindle Bore	夾持範圍 Chucking Area mm 直徑 Dia Max. 長度 Len Max.	容許油壓壓力 kgf/cm ² Max. Pressure	最大夾持力 kN (kgf) Max. Gripping Force	最高迴轉數 min ⁻¹ Max. Speed	慣性矩 kg*m ² Moment of Inertia	重量 kg Weight	客戶確認 Confirmed
IS-254	8X45,4X90	20	86+0.1	65 160	45	19.5	2400	0.41	41	

※訂購時請將圖面連同訂單一併回傳。 ※Please send back with order while ordering.

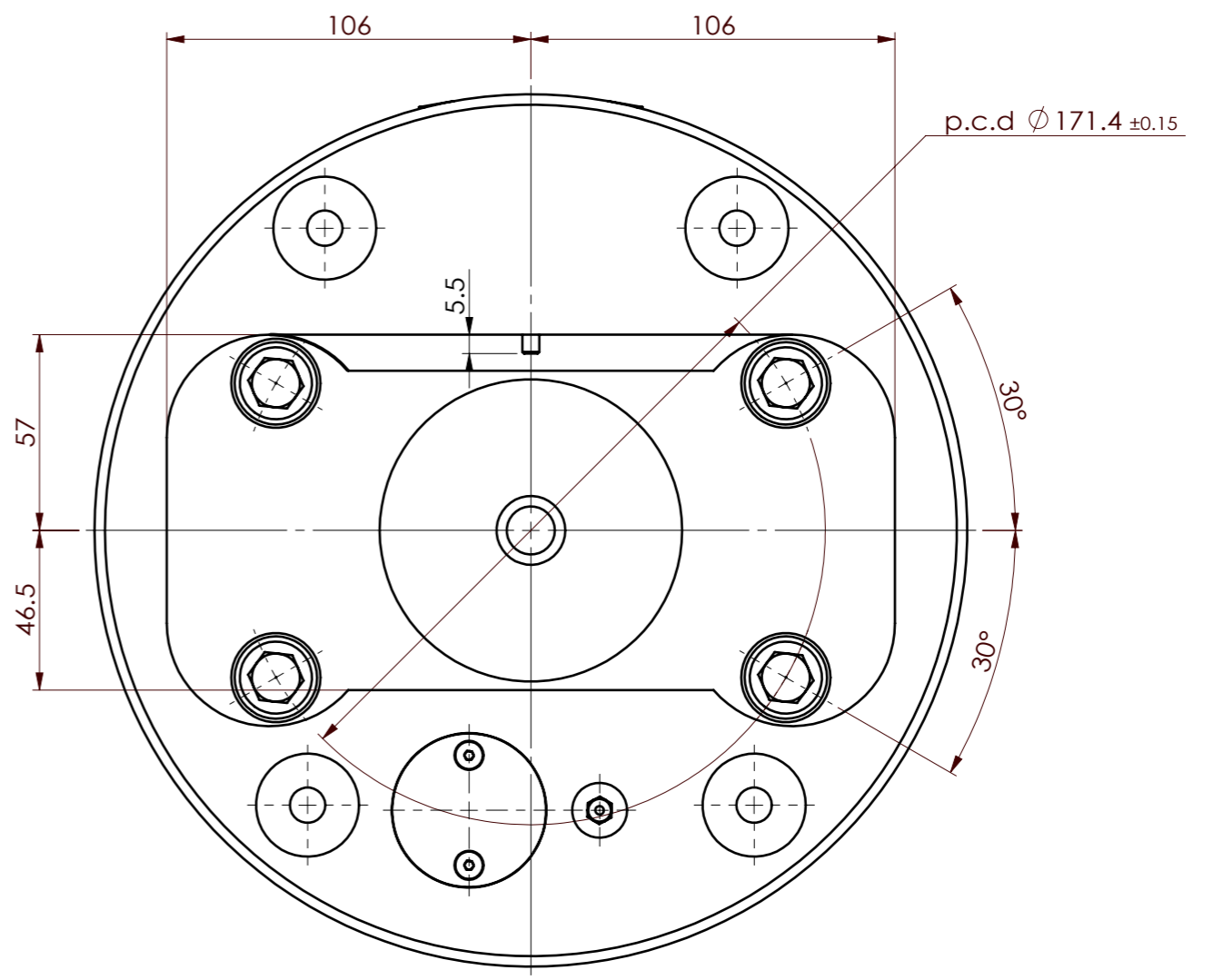
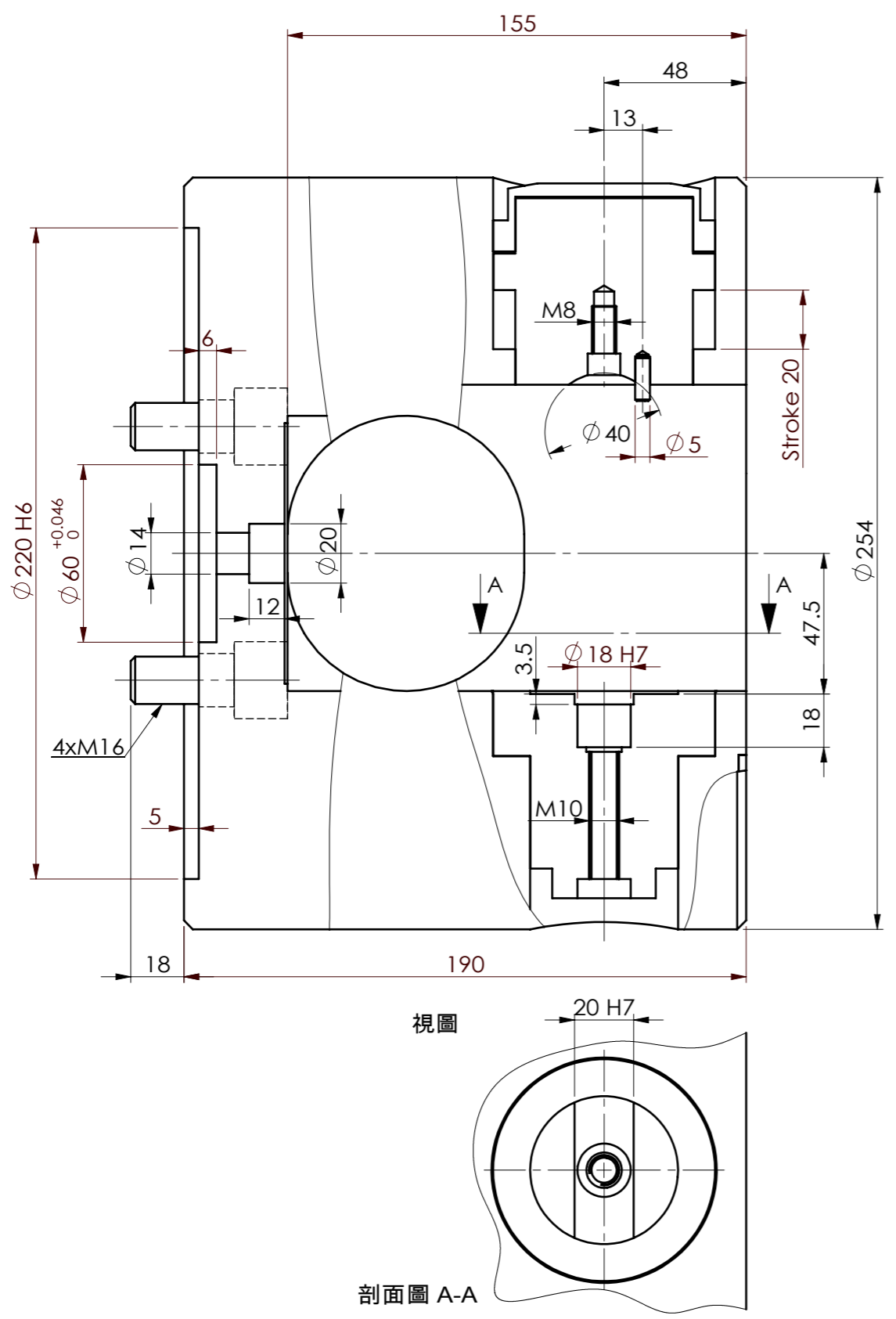

油壓自動分度夾頭

Power Indexing Chuck

※為確保產品品質日益精進，敝公司擁有設計變更之權。 ※Subject to technical changes.



佳賀精機股份有限公司
AUTOGrip MACHINERY CO., LTD.