

1	規格 Spec. 型號 Model	夾行程 mm Plunger Stroke	爪行程(直徑) mm Jaw Stroke (Dia.)	夾持直徑 Chucking Dia. mm 最大 Max.	最小 min.	容許油壓缸推力 kgf Max D.B. pull	最大夾持力 kgf Max clamping force	最高迴轉數 r.p.m. Max speed	重量 kg Weight
2	4V-15A8	35	16	381	72	8360	25000	2300	2.34
3									131
4									
5									
6									

*訂購時請將圖面連同訂單一併回傳。

*Please send back with order while ordering.

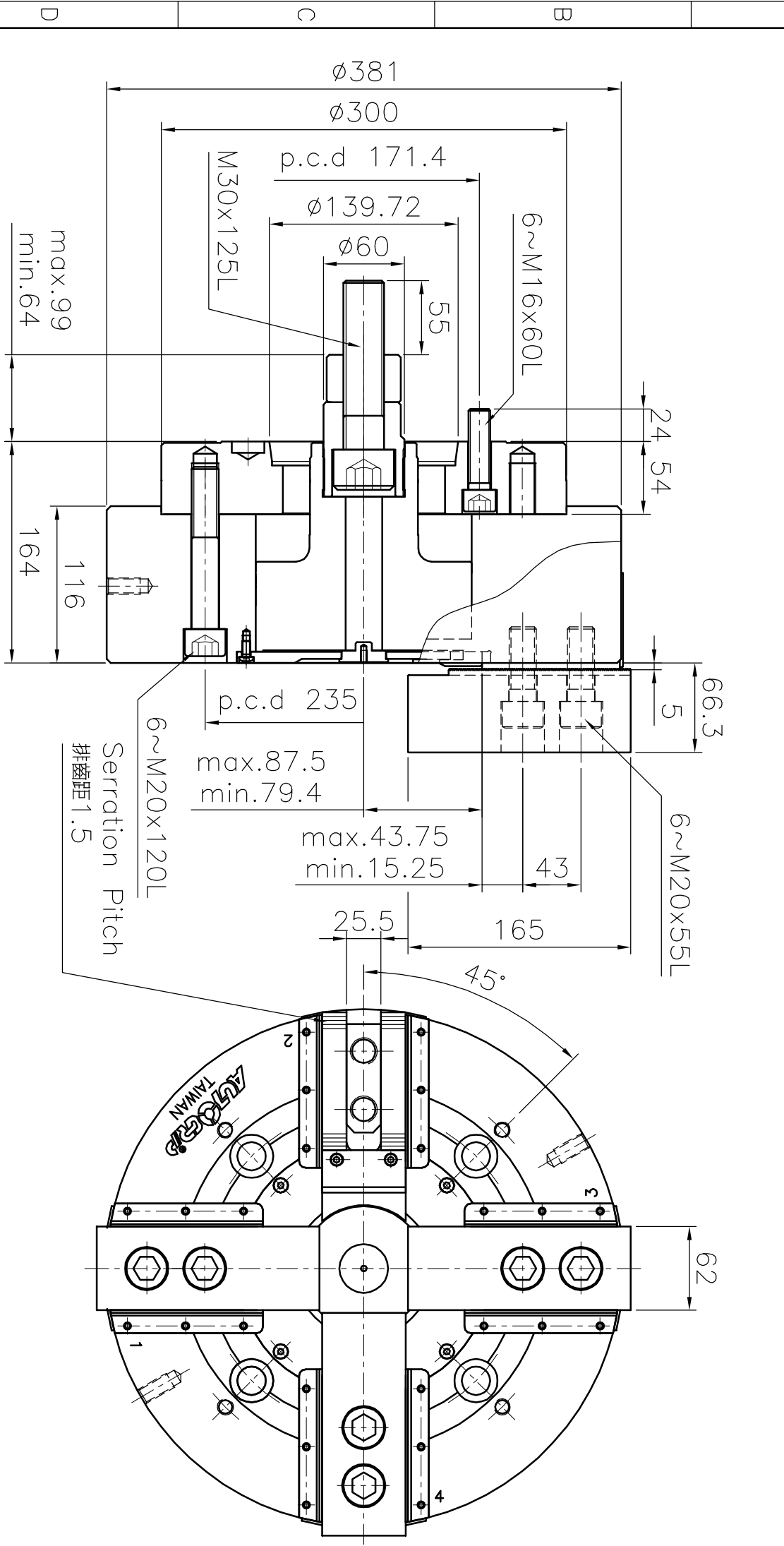

中實立車四爪夾頭