

TN

FEATURES

- Accuracy guaranteed to 0.003mm TIR (0.0001")
- Excellent for CNC, conventional machines and heavy-duty machining
- Heat-treated point to HRc 60
- Based on taper roller bearing assembly for superior performance.
- Carbide point available.
- Carbide point to HRa 90±5.

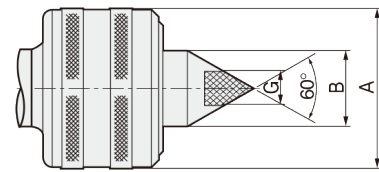
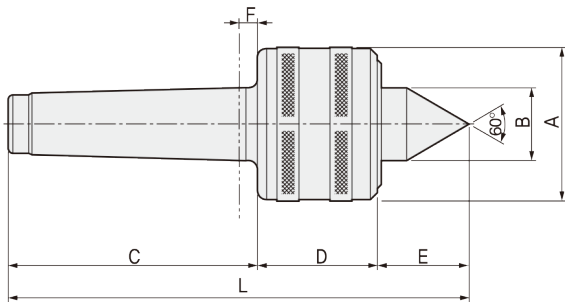

Available Carbide Tipped Points

TNC-TYPE

- MT3: 062003
- MT4: 062004
- MT5: 062005
- MT6: 062006

Dimension

Unit: mm. kg

MODEL	MT	A	B	C	D	E	F	G	L	Workpiece Weight	Max. R.P.M	Weight	Max. Run Out
061003 (062003)	3	51	25	85	44	28	6	10	157	400	4,000	0.8	0.003
061004 (062004)	4	66	32	108	52	40	8	14	200	650	3,000	1.8	0.003
061005 (062005)	5	94	40	136	70	45.5	8	18	251.5	2,500	2,000	4.3	0.003
061006 (062006)	6	127	58.5	189	92.7	61.5	10	30	343.3	4,500	1,000	12.5	0.005
061006H	6	168	80	191	120	84	10	-	395	8,000	800	20	0.005
061007	7	168	78.5	260	110	82	12	-	452	5,000	500	32	0.010
061008	7	177	78.5	260	124	80	12	-	464	10,000	500	34	0.010

*(MODEL NO) : Carbide Tip Type

TN type Technical data

- 3TN
- 4TN
- 5TN
- 6TN

