

UNH

FEATURES

- High speed product of UN type.
- Accuracy guaranteed to 0.003mm TIR (0.0001")
- Multi sealing (high performance lip seal and V-seal) protects from ingress by dust and coolant.
- Shorten maintenance time for automated CNC installations by longer product life.
- Heat-treated point to HRc 60 ± 2.
- Heat-treated body for extra strength, rigidity and long life.
- Carbide point available. (UNHC TYPE)
- Carbide point to HRA 90 ± 5.

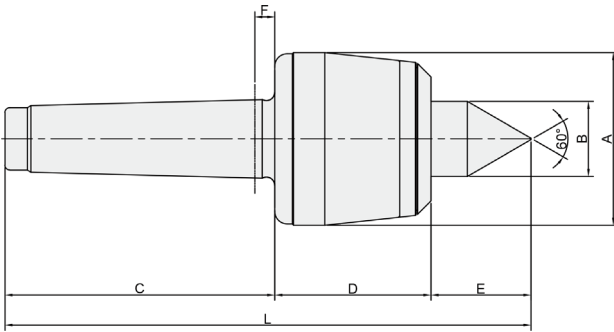

Available Carbide Tipped Points
UNHC-TYPE

- MT4: 172004
- MT5: 172005

Dimension

Unit: mm. kg

| MODEL | MT | A | B | C | D | E | F | G | L | Workpiece Weight | Max, R.P.M | Weight | Max, Run Out |
|--------------------|----|----|----|-----|------|------|---|----|-------|------------------|------------|--------|--------------|
| 171004 (172004) | 4 | 69 | 30 | 108 | 62.5 | 40 | 8 | 14 | 210.5 | 800 | 6,000 | 2 | 0.003 |
| 171005 (172005) | 5 | 88 | 38 | 136 | 79 | 50.5 | 8 | 18 | 265.5 | 2,000 | 5,000 | 5 | 0.003 |

* (MODEL NO) : Carbide Tip Type

UNH type Technical data

- 4UNH
- 5UNH

